

FISA TEHNICA PENTRU BENZI TRANSPORTATOARE

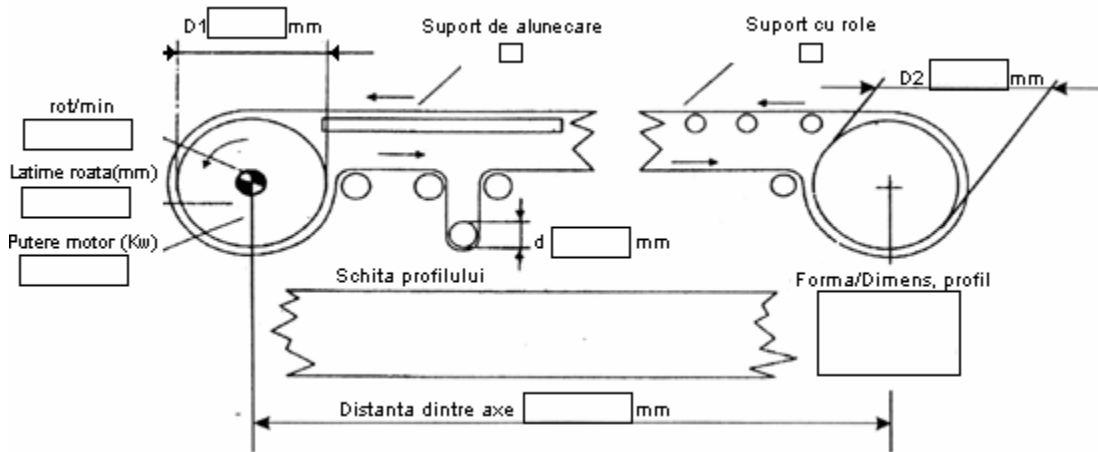









Denumirea utilajului:

Regim de exploatare: **ore/zi**

Latime banda: **mm** **Lungime banda:** **mm**

TIP BANDA TRANSPORTATOARE

- | | |
|--|---|
|  Cu suport de alunecare <input type="checkbox"/>
 Cu suport de alunecare si pe ramura de intoarcere <input type="checkbox"/>
 Jgheab cu role <input type="checkbox"/>
 Elevator <input type="checkbox"/>
 Banda cu traseu curbat <input type="checkbox"/> |  Cu suport cu role <input type="checkbox"/>
 Jgheab de alunecare <input type="checkbox"/>
 Unghi de inclinare α <input type="checkbox"/> grade
 Banda de acumulare <input type="checkbox"/> |
|--|---|

Produs transportat: Viteza banda: m/s Temperatura min.: °C Conditii de umiditate <input type="checkbox"/> Agenti chimici in contact <input type="checkbox"/> Industria alimentara (FDA) <input type="checkbox"/>	Masa transportata Kg/m Temperatura max: °C Cerinte de antistaticitate <input type="checkbox"/> Denumire agent chimic: Alte cerinte functional-constructive:
---	--

CERINTE DE IMBINARE SI LIVRARE

- | | |
|---|---|
| Livrat imbinat <input type="checkbox"/>
Pregatit pentru imbinare <input type="checkbox"/>
Imbinare termica <input type="checkbox"/> | Imbinare la beneficiar (pe utilaj) <input type="checkbox"/>
Livrat doar materialul <input type="checkbox"/>
Imbinare mecanica (cleme etc.) <input type="checkbox"/> |
|---|---|

Tip/Denumire/Cod material utilizat anterior:
(daca este cazul)

Cod material solicitat (vezi mostrar):
(daca este cazul)

Beneficiar:
Adresa:
Telefon: **Fax:**
Termen de livrare:

CHIORINO[®]
1906

**Produsor de
Benzi transportoare si curele late poliamidice**

Tel./Fax: 0264 432977

www.chiorino.ro